

TECHNICAL RIDER FOR

Shenanigans

By programming this performance, the organization commits to the technical requirements for this performance. This technical rider is part of the contract. If one of the requirements is not met, this could lead to the cancellation of the contract.

Contact

General: info@jamshenanigans.com
Crew / Artists: Batist Van Baekel +32493025631 (BE)
Henri Kangas +358503016198 (FIN)
Technician: Batist Van Baekel (BE) +32493025631,
batistvanbaekel@gmail.com

Do not hesitate to contact us either by email or mobile.

General information

Company: *Jam.Shenanigans*
Length: 50 minutes
Artists / Crew: 2, Henri Kangas (FIN) & Batist Van Baekel (BE)
Audience: +6
Target audience: Family (+6)
Capacity: preferably between 100 - 300 people (open for discussion)
Theater technicians needed: 1-2
Setting: Frontal

Time frame

The time frame is always depending on the specifics of the location and performance time. We count on a minimum build-up time of 4 hours, and approx. 1 hour of breakdown time. Build-up times include the hanging and focusing of the lights. The stage must be ready at least 1 hour before show time, for the preparations of the artists on stage. All technical preparations must be finished before this last hour. We require 1 to 2 technicians from the house to assist with the buildup of light and sound. The performance is approximately 50 minutes long. It is possible to perform up to 2 times a day when there is a minimum break time of 2 hours in between both shows.

Stage

Shenanigans is an indoor performance and can't be performed outside. The minimum floor size is 6x4m, but ideally 8x6m. The floor must be flat, hard, stable, even and clean, preferably covered with a black dance floor. The minimum free height above the entire stage must be 4m. Please contact us when these requirements are not met. Depending on the situation, adjustments might be possible. Wings are needed on both sides. The stage must be ready at least 1 hour before show time, for the preparations of the artists on stage.

For the best eyesight, the audience should be seated on a tribune with the stage preferably lower than the seating. The audience seating should be easily accessible from the stage for the audience interaction scenes during the performance.

Technical details

The sound and light during the performance are controlled by the artists from the stage.. *Shenanigans*, lights and sound, are pre-programmed on Q-Lab and set up on a laptop (provided by the artists). During the performance, the artists control the light and sound through a button/midi controller (provided by the artist) that is connected to their laptop (central device).

No technician is needed during the performance to activate cues neither for light nor sounds. Help is needed from house technicians during build-up and breakdown. Batist Van Baekel is a trained lighting designer and technician and will be the leader and contact concerning light and sound.

Batist Van Baekel +32493025631 (Dutch, English)

Sound

We use the PA system from the location. We need 1 stereo input channel (computer, 3.5mm jack) in the wing stage right/jardin. We will bring our own laptop.

Light

We use the lighting installation from the location. We need a DMX input to the main dimmers (max 2 universes) in the same wing as the audio input (stage right/jardin). The performers will provide a laptop (with their own lighting programs) and a DMX controller. See attached drawings for further information on the lighting plan.

Transport

This performance travels by public transport. We will arrive at the nearest train station. If the performance location isn't easily reachable by public transport, the organization is responsible for arranging a solution. Travel costs are at the expense of the organization. When it isn't possible to travel back home by public transport after the performance, the organization needs to arrange accommodation.

Dressing room & Accommodation

A dressing room nearby to the stage is required. The dressing room should contain a table, chairs, mirror, clothing rack and running water (preferably a shower).

When performing multiple days in a row or the possibility of traveling back home after the performance by public transport isn't available anymore, accommodation should be arranged by the organization. We require 2 single bedrooms. When we perform multiple days, the costumes need to be washed daily. In that case, a washing machine needs to be available for use

Green Rider/Catering

As a company, we are trying to keep our ecological footprint as low as possible. Next to traveling by public transport, we wish for as little plastic and preferably local product for the catering. We prefer fruits and nuts above chocolate or cookies wrapped in plastic. No plastic water bottles need to be arranged, the crew will take their own water bottles. During our stay, we expect that 1 meal is arranged. This can be breakfast, lunch or dinner, depending on the day planning, and the number of performances. All of our crew have a vegetarian diet (no meat, no fish), and one of the two performers is also gluten intolerant.







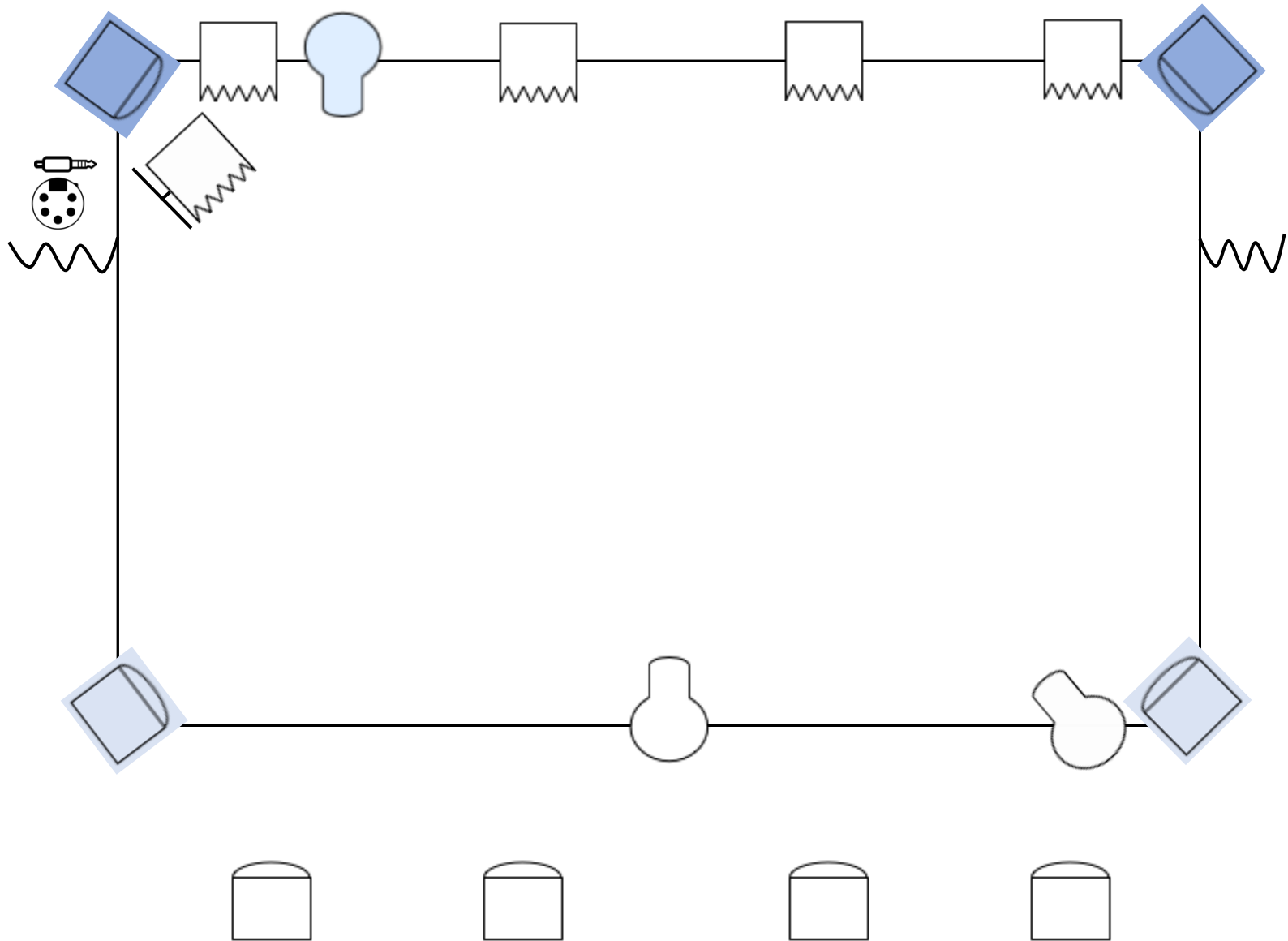

Recording

No video recording of *Shenanigans* is allowed without the permission of the artists. If the performance is recorded, *Jam.Shenanigans* wants a high-quality copy with unrestricted use.

(Light plan to be added in the near future)

Light plan Shenanigans – Jam.Shenanigans

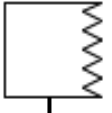

	PC		Fixture with 502 filter		3.5 Mini jack
	Fresnel		Fixture with 501 filter		DMX input
	Profile		Fresnel on floor stand		Wing

Technical contact: batistvanbaekel@gmail.com or 0032493025631

General info: info@jamshenanigans.com